

4

3

2

1

CROWN LINK®

專業薄膜開關連接器第一品牌



RoHS

◆ SPECIFICATIONS

- VOLTAGE RATING: 250 V AC , DC
- CURRENT RATING: 3 A AC , DC
- CONTACT RESISTANCE: 20 mΩ MAX
- INSULATION RESISTANCE: 1000 MΩ MIN
- WITHSTANDING VOLTAGE: 1500V AC / MINUTE

◆ ENVIRONMENTAL

- TEMPERATURE RANGE: -40°C~+105°C

◆ PART NO.

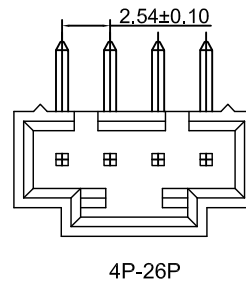
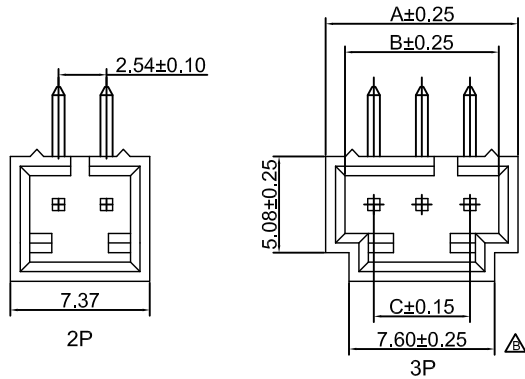
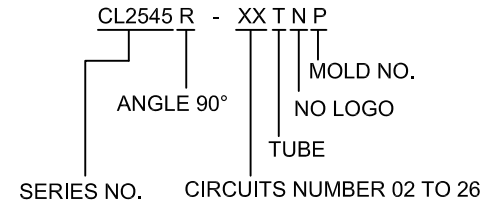

02PIN-15PIN 6.85±0.30
≥16PIN 6.35±0.30

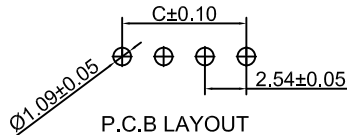
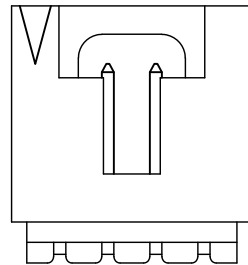
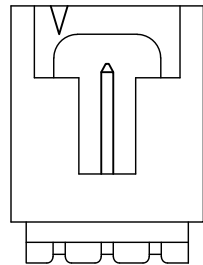
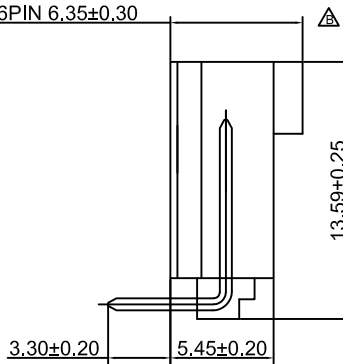

Part NO.	Dimensions			Part NO.	Dimensions		
	A	B	C		A	B	C
CL2545R-02TNP	7.37	5.33	2.54	CL2545R-15TNP	40.65	38.61	35.56
CL2545R-03TNP	10.17	8.13	5.08	CL2545R-16TNP	43.19	41.15	38.10
CL2545R-04TNP	12.71	10.67	7.62	CL2545R-17TNP	45.73	43.69	40.64
CL2545R-05TNP	15.25	13.21	10.16	CL2545R-18TNP	48.27	46.23	43.18
CL2545R-06TNP	17.79	15.75	12.70	CL2545R-19TNP	50.81	48.77	45.72
CL2545R-07TNP	20.33	18.29	15.24	CL2545R-20TNP	53.35	51.31	48.26
CL2545R-08TNP	22.87	20.83	17.78	CL2545R-21TNP	55.89	53.85	50.80
CL2545R-09TNP	25.41	23.37	20.23	CL2545R-22TNP	58.43	56.39	53.34
CL2545R-10TNP	27.95	25.91	22.86	CL2545R-23TNP	60.97	58.93	55.88
CL2545R-11TNP	30.49	28.45	25.40	CL2545R-24TNP	63.51	61.47	58.42
CL2545R-12TNP	33.03	30.99	27.94	CL2545R-25TNP	66.05	64.01	60.96
CL2545R-13TNP	35.57	33.53	30.48	CL2545R-26TNP	68.59	66.55	63.50
CL2545R-14TNP	38.11	36.07	33.02				

REV/版本	MODIFIED CONTENT /變更內容	DRAWN/繪圖	DATE/日期	TOLERANCE RANGE/公差範圍
B	DIMENSION CORRECTION	JUDY	2024.04.02	X. ±0.50 .X ±0.30 .XX ±0.20 .XXX ±0.05
A	FIRST DRAWING	UNA	2019.01.08	X.* ±1° .X.* ±0.1° .XX.* ±0.01° .XXX.* ±0.005°

DRAWN/繪圖	DATE/日期
UNA	2019.01.08
CHECK BY/審查	DATE/日期
VIVIAN	2019.01.08
APPROVED BY/核准	DATE/日期
WENDY	2019.01.08
PACKAGE/包裝	TUBE

CROWN LINK® THE LEADING MANUFACTURER OF FPC & FFC CONNECTOR, HOUSING AND DOME.					
PRODUCT NAME/品名: 2.54mm PITCH 90° WAFER					
PART NO./料號	PIN NUMBER/針數	SCALE/比例	SIZE/圖號	UNIT/單位	
CL2545R-XXTNP	2-26 PIN	2.5:1	A4	mm	
MATERIAL/材質	COLOR/顏色	ANGLE OF VIEW/視角	SHEET/頁碼	REV/版本	
PBT UL 94V-0	BLACK COLOR		1 OF 1	B	