

4

3

2

1

# CROWN LINK<sup>®</sup>

專業薄膜開關連接器第一品牌

ROHS

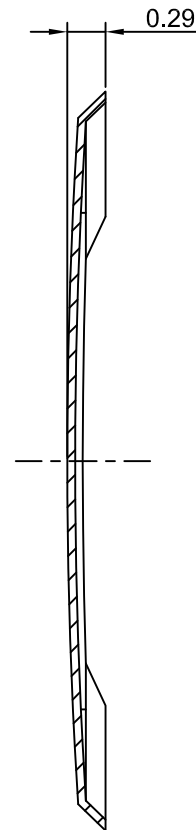
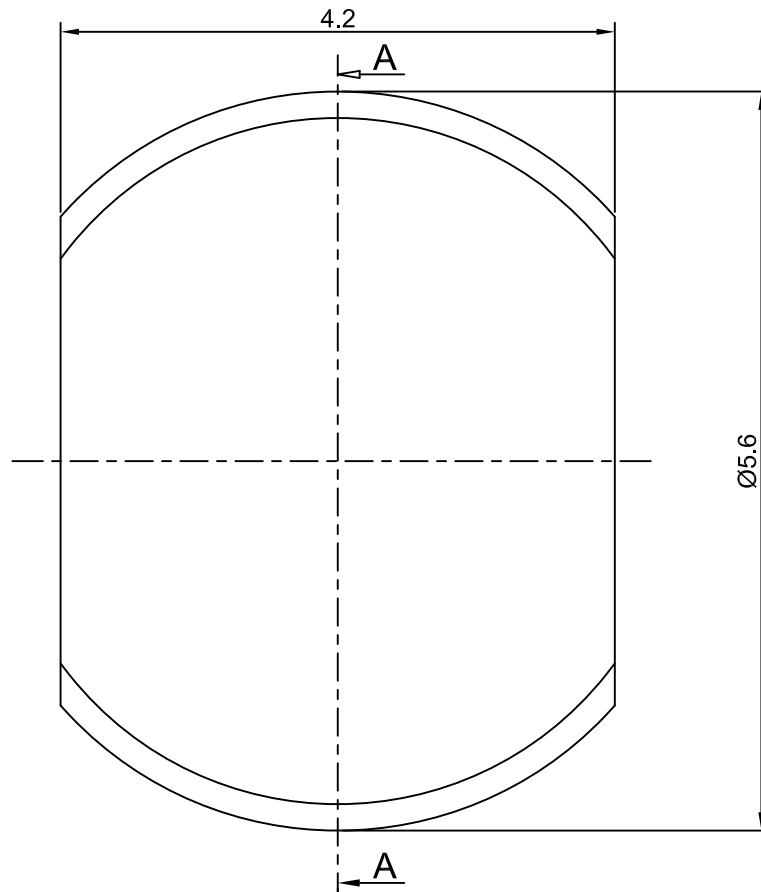

SECTION A - A

◆ SPECIFICATIONS

TRIP FORCE: 180 ± 30 g

CLICK RATIO: MIN 25 %

◆ TESTING CONDITIONS

FORCE TEST PROBE: HARD POINTED

LIFE TEST PROBE: RB 60° SILICON ROUND HEAD

LIFE TEST FORCE: 230 g

LIFE TEST SPEED: 180 CYCLE / MIN

BURR: MAX 0.05 MM

UNLESS OTHERWISE SPECIFIED TESTING METHOD  
ACCORDING TO CROWNLINK STANDARD PROCEDURE

				X.XX ±0.10 TOLERANCE RANGE/公差範圍
A	FIRST DRAWING	ANNIE	2013.08.16	
REV/版本	MODIFIED CONTENT /變更內容	DRAWN/繪圖	DATE/日期	

DRAWN/繪圖 ANNIE	DATE/日期 2013.08.16	<b>CROWN LINK<sup>®</sup> THE LEADING MANUFACTURER OF FPC &amp; FFC CONNECTOR, HOUSING AND DOME.</b>				
CHECK BY/審查 VIVIAN	DATE/日期 2013.08.16	PRODUCT NAME/品名 METAL DOME				
APPROVED BY/核准 JASON	DATE/日期 2013.08.16	PART NO./料號 CL5.6-ESN-180T	THICKNESS/厚度 0.06 mm	SCALE/比例 18:1	SIZE/圖號 A4	UNIT/單位 mm
PACKAGE/包裝	10,000PCS/BAG	MATERIAL/材質 STAINLESS STEEL SUS 304		ANGLE OF VIEW/視角 	SHEET/頁碼 1 OF 1	REV/版本 A