

4

3

2

1

# CROWN LINK<sup>®</sup>

專業薄膜開關連接器第一品牌

ROHS

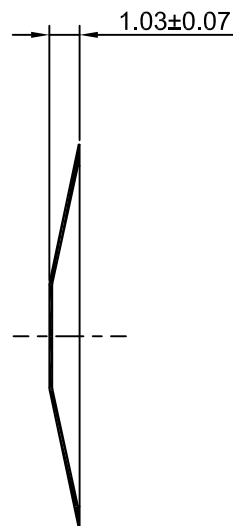
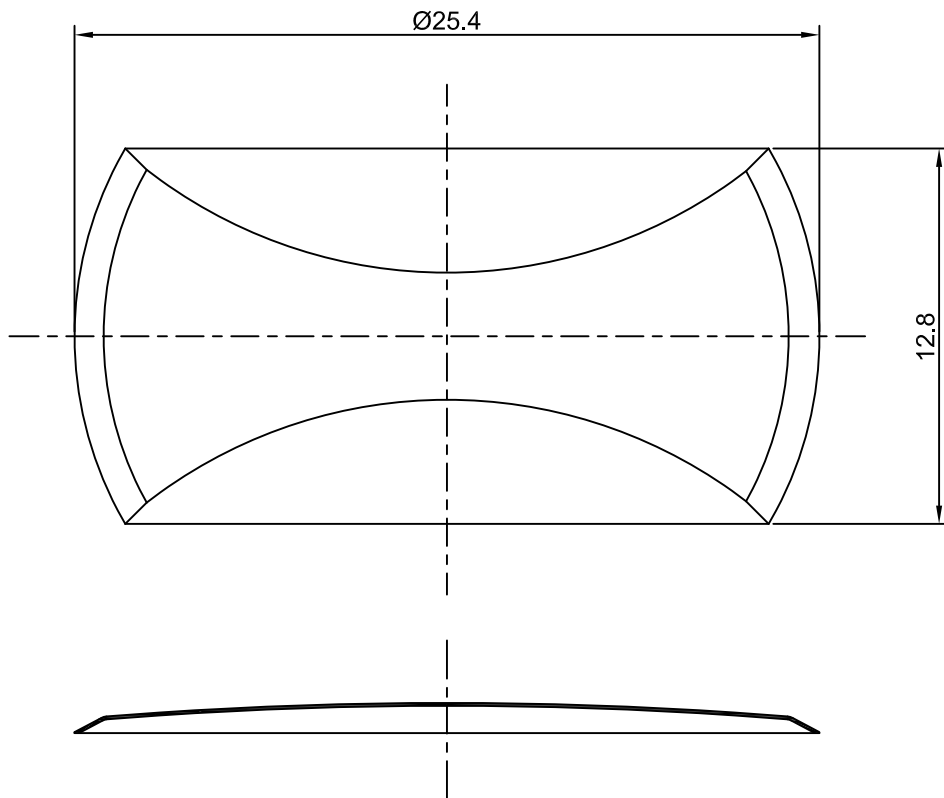

- ◆ SPECIFICATIONS
  - TRIP FORCE: 350 ± 30 g
  - CLICK RATIO: MIN 45 %
- ◆ TESTING CONDITIONS
  - FORCE TEST PROBE: HARD POINTED
  - LIFE TEST PROBE: RB 60° SILICON ROUND HEAD
  - LIFE TEST FORCE: 420 g
  - LIFE TEST SPEED: 180 CYCLE / MIN
  - BURR: MAX 0.05 MM
  - UNLESS OTHERWISE SPECIFIED TESTING METHOD ACCORDING TO CROWNLINK STANDARD PROCEDURE

				X.XX ±0.10
A	FIRST DRAWING	ANNIE	2013.08.16	
REV/版本	MODIFIED CONTENT /變更內容	DRAWN/繪圖	DATE/日期	

DRAWN/繪圖	DATE/日期	<b>CROWN LINK<sup>®</sup> THE LEADING MANUFACTURER OF FPC &amp; FFC CONNECTOR, HOUSING AND DOME.</b>			
ANNIE	2013.08.16	PRODUCT NAME/品名 METAL DOME			
CHECK BY/審查	DATE/日期	PART NO./料號	THICKNESS/厚度	SCALE/比例	SIZE/圖號
VIVIAN	2013.08.16	CL25.4-ESN-350T	0.10 mm	4:1	A4
APPROVED BY/核准	DATE/日期	MATERIAL/材質	ANGLE OF VIEW/視角	SHEET/頁碼	REV/版本
JASON	2013.08.16	STAINLESS STEEL SUS 304	⊕	1 OF 1	A
PACKAGE/包裝	10,000PCS/BAG				