

4

3

2

1

# CROWN LINK®

專業薄膜開關連接器第一品牌

ROHS

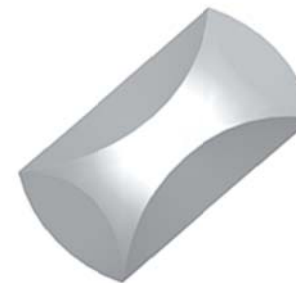
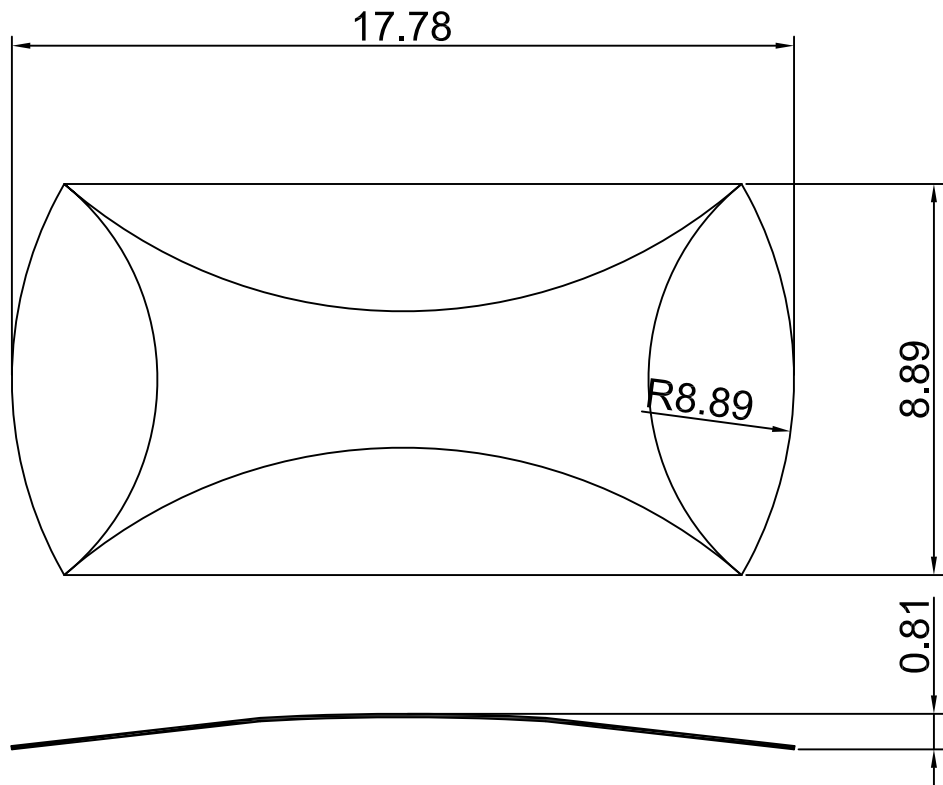

◆ SPECIFICATIONS

TRIP FORCE: 350 ± 30 g  
CLICK RATIO: MIN 45 %

◆ TESTING CONDITIONS

FORCE TEST PROBE: HARD POINTED  
LIFE TEST PROBE: RB 60° SILICON ROUND HEAD  
LIFE TEST FORCE: 420 g  
LIFE TEST SPEED: 180 CYCLE / MIN  
BURR: MAX 0.05 MM  
UNLESS OTHERWISE SPECIFIED TESTING METHOD  
ACCORDING TO CROWNLINK STANDARD PROCEDURE

				X.XX ±0.10
A	FIRST DRAWING	ANNIE	2013.08.28	
REV/版本	MODIFIED CONTENT /變更內容	DRAWN/繪圖	DATE/日期	

TOLERANCE RANGE/公差範圍

DRAWN/繪圖	DATE/日期	<b>CROWN LINK® THE LEADING MANUFACTURER OF FPC &amp; FFC CONNECTOR, HOUSING AND DOME.</b>			
ANNIE	2013.08.28	PRODUCT NAME/品名 METAL DOME			
CHECK BY/審查	DATE/日期	PART NO./料號	THICKNESS/厚度	SCALE/比例	SIZE/圖號
VIVIAN	2013.08.28	CL17.78-ESN-350T	0.08 mm	6:1	A4
APPROVED BY/核准	DATE/日期	MATERIAL/材質	ANGLE OF VIEW/視角	SHEET/頁碼	REV/版本
JASON	2013.08.28	STAINLESS STEEL SUS 304	⊕	1 OF 1	A
PACKAGE/包裝	10,000PCS/BAG				

D

D

C

C

B

B

A

A