

4

3

2

1

CROWN LINK[®]

專業薄膜開關連接器第一品牌

ROHS

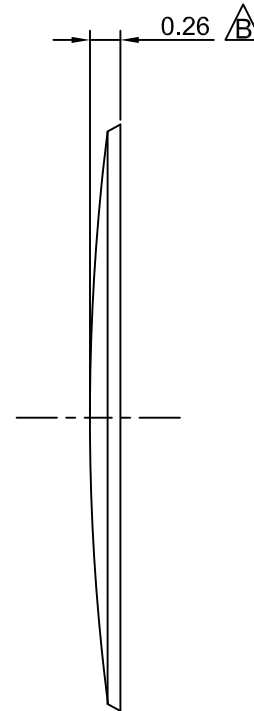
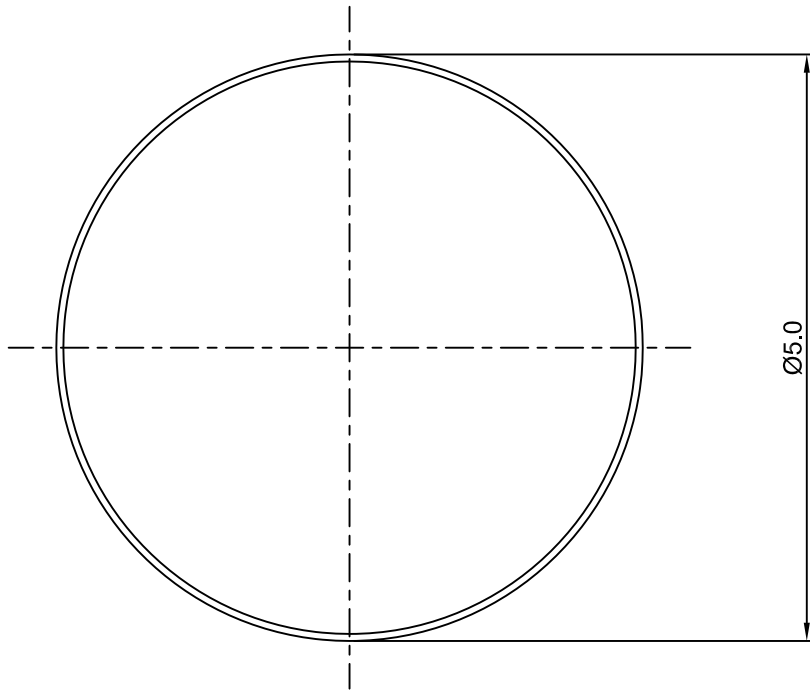

◆ SPECIFICATIONS

TRIP FORCE: 250 ± 30 g

CLICK RATIO: MIN 35 %

◆ TESTING CONDITIONS

FORCE TEST PROBE: HARD POINTED

LIFE TEST PROBE: RB 60° SILICON ROUND HEAD

LIFE TEST FORCE: 310 g

LIFE TEST SPEED: 180 CYCLE / MIN

BURR: MAX 0.05 MM

UNLESS OTHERWISE SPECIFIED TESTING METHOD

ACCORDING TO CROWNLINK STANDARD PROCEDURE

C	NEW DRAWING FORMAT	ANNIE	2013.08.20	X.XX ±0.10
B	CONVERT TO NEW DRAWING FORMAT & REVISE DOME HEIGHT	ANNIE	2005.02.25	
A	FIRST DRAWING	ANNIE	2004.02.20	
REV/版本	MODIFIED CONTENT /變更內容	DRAWN/繪圖	DATE/日期	

DRAWN/繪圖	DATE/日期	CROWN LINK[®] THE LEADING MANUFACTURER OF FPC & FFC CONNECTOR, HOUSING AND DOME.				
ANNIE	2013.08.20	PRODUCT NAME/品名				
CHECK BY/審查	DATE/日期	METAL DOME				
VIVIAN	2013.08.20	PART NO./料號	THICKNESS/厚度	SCALE/比例	SIZE/圖號	UNIT/單位
APPROVED BY/核准	DATE/日期	CL5-RSN-250T	0.06 mm	16:1	A4	mm
JASON	2013.08.20	MATERIAL/材質	ANGLE OF VIEW/視角		SHEET/頁碼	REV/版本
PACKAGE/包裝	10,000PCS/BAG	STAINLESS STEEL SUS 304			1 OF 1	C