

4

3

2

1

CROWN LINK®

專業薄膜開關連接器第一品牌

ROHS

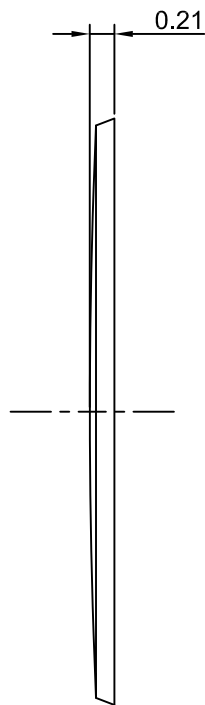
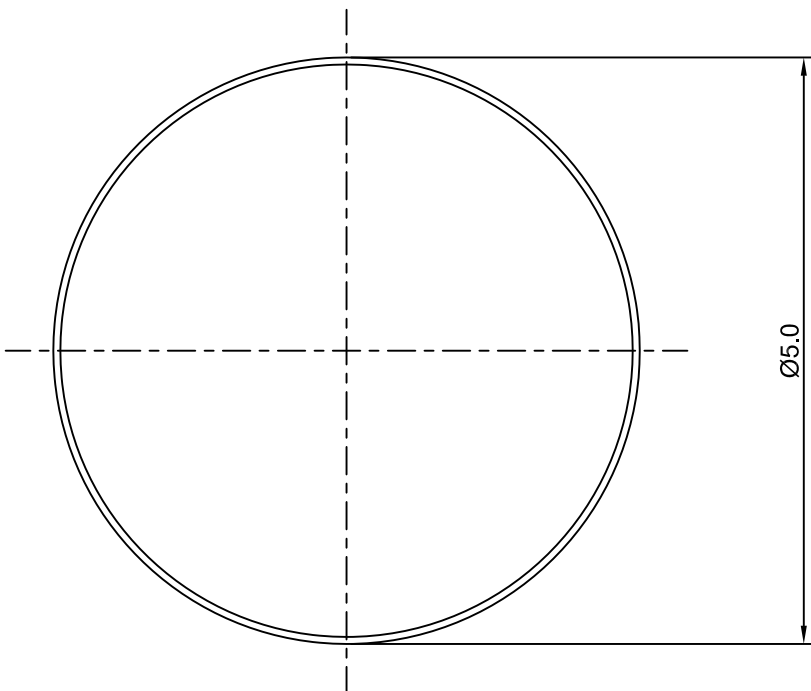

- ◆ SPECIFICATIONS
 - TRIP FORCE: 150 ± 30 g
 - CLICK RATIO: MIN 25 %
- ◆ TESTING CONDITIONS
 - FORCE TEST PROBE: HARD POINTED
 - LIFE TEST PROBE: RB 60° SILICON ROUND HEAD
 - LIFE TEST FORCE: 200 g
 - LIFE TEST SPEED: 180 CYCLE / MIN
 - BURR: MAX 0.05 MM
 - UNLESS OTHERWISE SPECIFIED TESTING METHOD ACCORDING TO CROWNLINK STANDARD PROCEDURE

				X.XX ±0.10
B	NEW DRAWING FORMAT	ANNIE	2013.08.27	
A	FIRST DRAWING	ANNIE	2004.02.20	
REV/版本	MODIFIED CONTENT /變更內容	DRAWN/繪圖	DATE/日期	
				TOLERANCE RANGE/公差範圍

DRAWN/繪圖	DATE/日期	CROWN LINK® THE LEADING MANUFACTURER OF FPC & FFC CONNECTOR, HOUSING AND DOME.			
ANNIE	2013.08.27	PRODUCT NAME/品名 METAL DOME			
CHECK BY/審查	DATE/日期	PART NO./料號	THICKNESS/厚度	SCALE/比例	SIZE/圖號
VIVIAN	2013.08.27	CL5-RNN-150T	0.06 mm	16:1	A4
APPROVED BY/核准	DATE/日期	MATERIAL/材質	ANGLE OF VIEW/視角	SHEET/頁碼	REV/版本
JASON	2013.08.27	DOUBLE SIDE NICKEL PLATED STAINLESS STEEL SUS 304	16:1	1 OF 1	B
PACKAGE/包裝	10,000PCS/BAG				

D

D

C

C

B

B

A

A