

4

3

2

1

CROWN LINK[®]

專業薄膜開關連接器第一品牌

ROHS

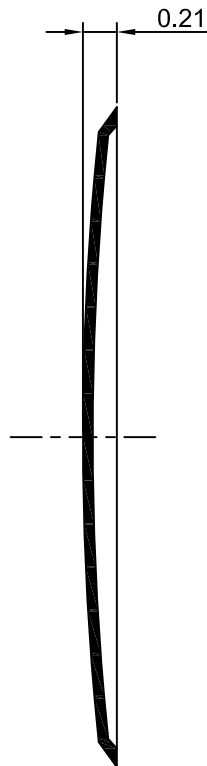
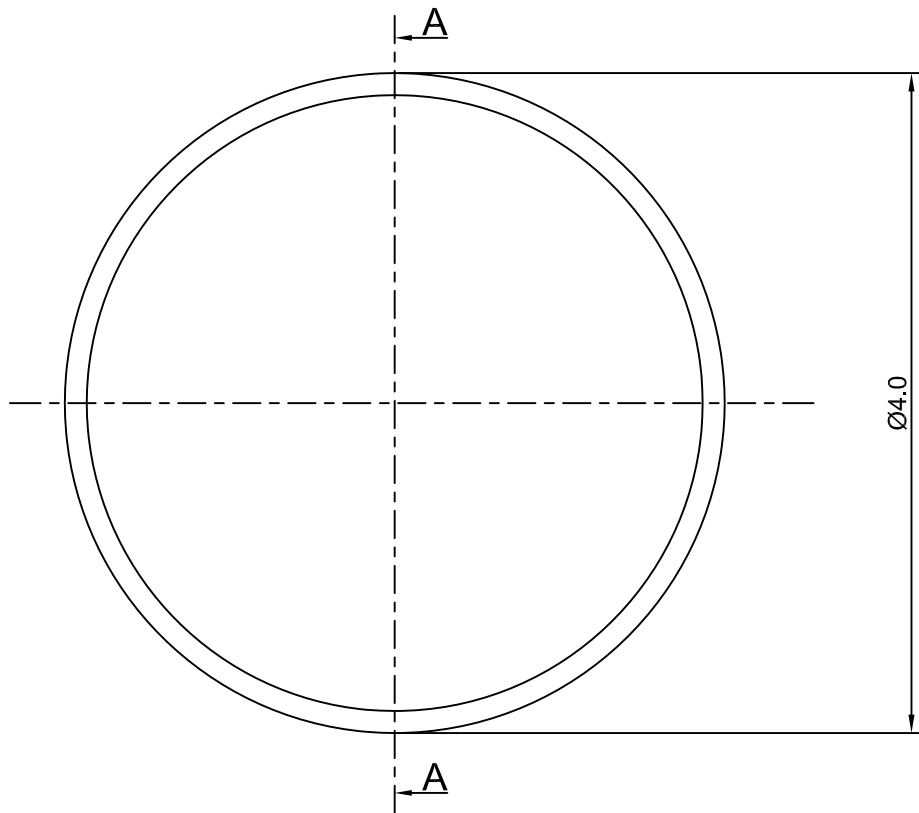

- ◆ SPECIFICATIONS
 - TRIP FORCE: 200 ± 30 g
 - CLICK RATIO: MIN 30 %
- ◆ TESTING CONDITIONS
 - FORCE TEST PROBE: HARD POINTED
 - LIFE TEST PROBE: RB 60° SILICON ROUND HEAD
 - LIFE TEST FORCE: 255 g
 - LIFE TEST SPEED: 180 CYCLE / MIN
 - BURR: MAX 0.05 MM
 - UNLESS OTHERWISE SPECIFIED TESTING METHOD ACCORDING TO CROWNLINK STANDARD PROCEDURE

SECTIONA-A

				X.XX ±0.10
A	FIRST DRAWING	ANNIE	2013.08.20	
REV/版本	MODIFIED CONTENT /變更內容	DRAWN/繪圖	DATE/日期	
TOLERANCE RANGE/公差範圍				

DRAWN/繪圖	DATE/日期	CROWN LINK[®] THE LEADING MANUFACTURER OF FPC & FFC CONNECTOR, HOUSING AND DOME.				
ANNIE	2013.08.20	PRODUCT NAME/品名 METAL DOME				
CHECK BY/審查	DATE/日期	PART NO./料號	THICKNESS/厚度	SCALE/比例	SIZE/圖號	UNIT/單位
VIVIAN	2013.08.20	CL4-RSN-200T	0.06 mm	22:1	A4	mm
APPROVED BY/核准	DATE/日期	MATERIAL/材質		ANGLE OF VIEW/視角	SHEET/頁碼	REV/版本
JASON	2013.08.20	STAINLESS STEEL SUS 304		⊕	1 OF 1	C
PACKAGE/包裝	10,000PCS/BAG					

D

D

C

C

B

B

A

A