

4

3

2

1

CROWN LINK[®]

專業薄膜開關連接器第一品牌

ROHS



◆ SPECIFICATIONS

TRIP FORCE: 140 ± 30 g

CLICK RATIO: MIN 10 %

◆ TESTING CONDITIONS

FORCE TEST PROBE: HARD POINTED

LIFE TEST PROBE: RB 60° SILICON ROUND HEAD

LIFE TEST FORCE: 190 g

LIFE TEST SPEED: 180 CYCLE / MIN

BURR: MAX 0.05 MM

UNLESS OTHERWISE SPECIFIED TESTING METHOD

ACCORDING TO CROWNLINK STANDARD PROCEDURE

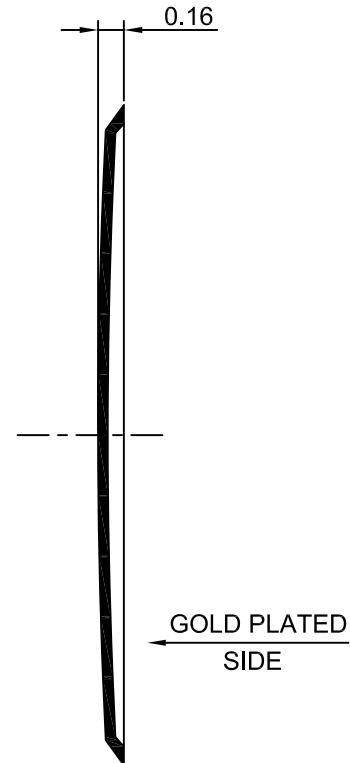
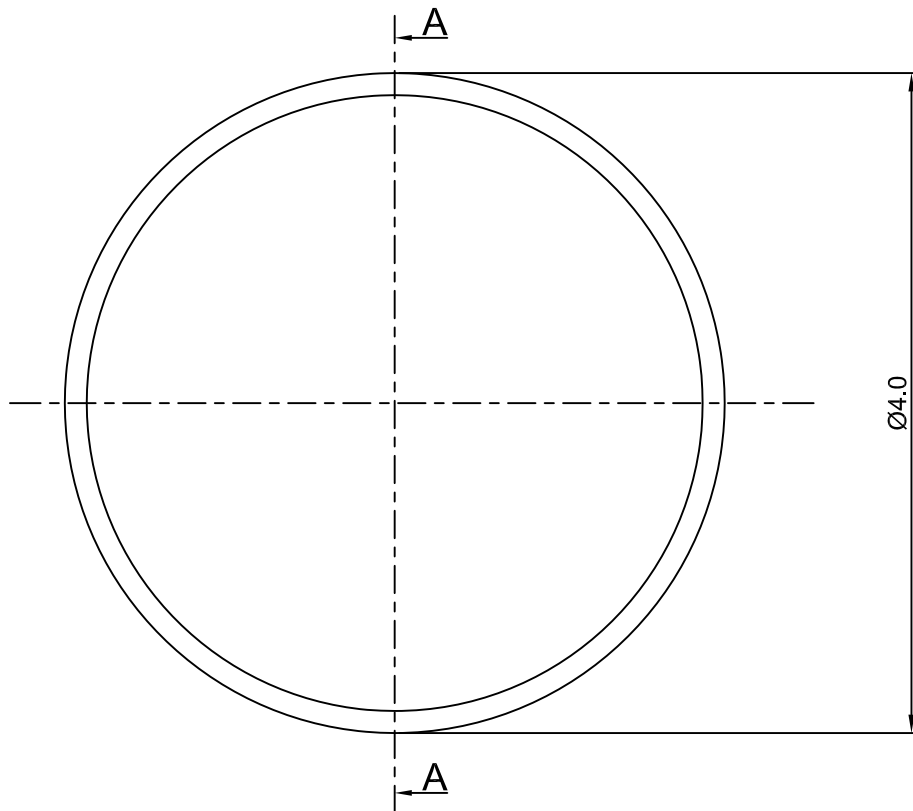

SECTION A-A

				X.XX ±0.10
A	FIRST DRAWING	ANNIE	2013.08.19	
REV/版本	MODIFIED CONTENT /變更內容	DRAWN/繪圖	DATE/日期	TOLERANCE RANGE/公差範圍

DRAWN/繪圖	DATE/日期	CROWN LINK[®] THE LEADING MANUFACTURER OF FPC & FFC CONNECTOR, HOUSING AND DOME.				
ANNIE	2013.08.19	PRODUCT NAME/品名 METAL DOME				
CHECK BY/審查	DATE/日期	PART NO./料號	THICKNESS/厚度	SCALE/比例	SIZE/圖號	UNIT/單位
VIVIAN	2013.08.19	CL4-RGN-140T	0.06 mm	22:1	A4	mm
APPROVED BY/核准	DATE/日期	MATERIAL/材質		ANGLE OF VIEW/視角	SHEET/頁碼	REV/版本
JASON	2013.08.19	SINGLE SIDE GOLD PLATED		1 OF 1	1 OF 1	A
PACKAGE/包裝		STAINLESS STEEL SUS 304				
	10,000PCS/BAG					