

4

3

2

1

CROWN LINK[®]

專業薄膜開關連接器第一品牌

ROHS

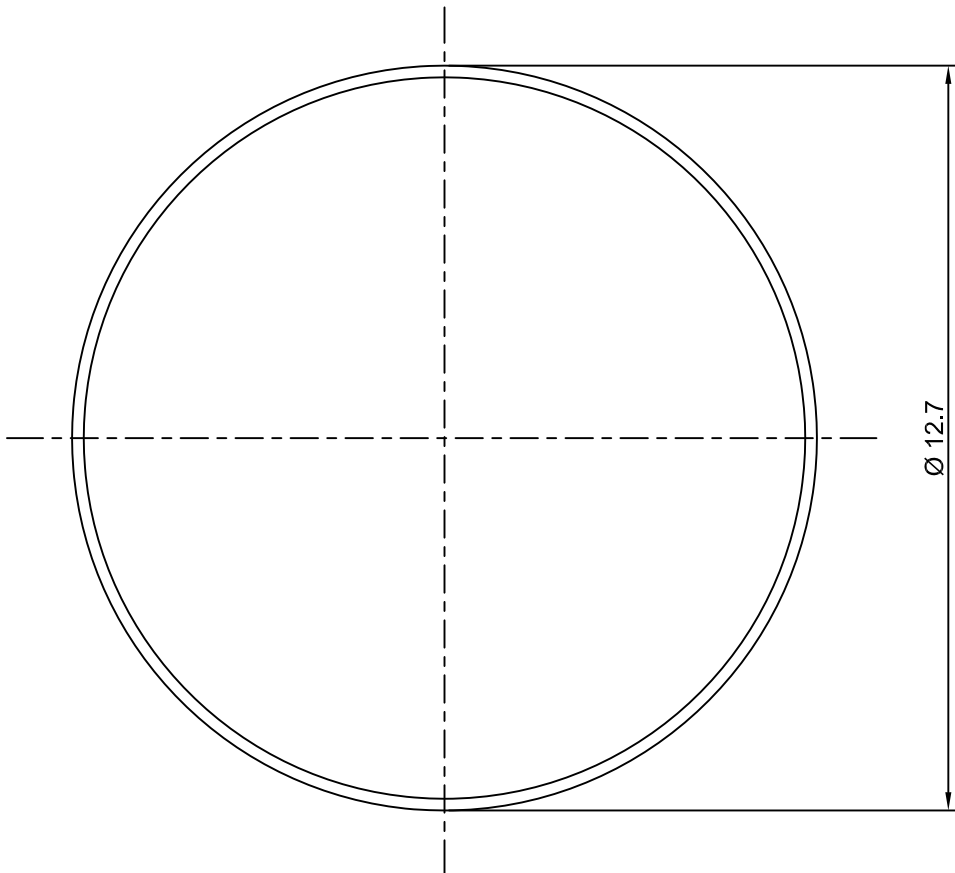

- ◆ SPECIFICATIONS
 - TRIP FORCE: 280 ± 30 g
 - CLICK RATIO: MIN 35 %
- ◆ TESTING CONDITIONS
 - FORCE TEST PROBE: HARD POINTED
 - LIFE TEST PROBE: RB 60° SILICON ROUND HEAD
 - LIFE TEST FORCE: 340 g
 - LIFE TEST SPEED: 180 CYCLE / MIN
 - BURR: MAX 0.05 MM
 - UNLESS OTHERWISE SPECIFIED TESTING METHOD ACCORDING TO CROWNLINK STANDARD PROCEDURE

C	NEW DRAWING FORMAT	ANNIE	2013.08.22
B	CONVERT TO NEW DRAWING FORMAT	ANNIE	2012.11.05
A	FIRST DRAWING	ANNIE	2004.02.20
REV/版本	MODIFIED CONTENT /變更內容	DRAWN/繪圖	DATE/日期

X.XX ±0.10
TOLERANCE RANGE/公差範圍

DRAWN/繪圖 ANNIE	DATE/日期 2013.08.22	CROWN LINK[®] THE LEADING MANUFACTURER OF FPC & FFC CONNECTOR, HOUSING AND DOME.				
CHECK BY/審查 VIVIAN	DATE/日期 2013.08.22	PRODUCT NAME/品名 METAL DOME				
APPROVED BY/核准 JASON	DATE/日期 2013.08.22	PART NO./料號 CL12.7-RSN-280T	THICKNESS/厚度 0.10 mm	SCALE/比例 10:1	SIZE/圖號 A4	UNIT/單位 mm
PACKAGE/包裝	10,000PCS/BAG	MATERIAL/材質 STAINLESS STEEL SUS 304		ANGLE OF VIEW/視角 	SHEET/頁碼 1 OF 1	REV/版本 C

D

D

C

C

B

B

A

A