

4

3

2

1

CROWN LINK[®]

專業薄膜開關連接器第一品牌

ROHS

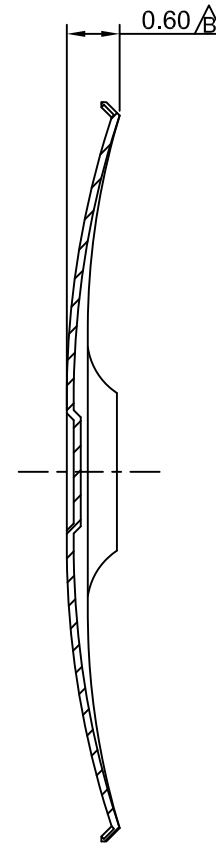
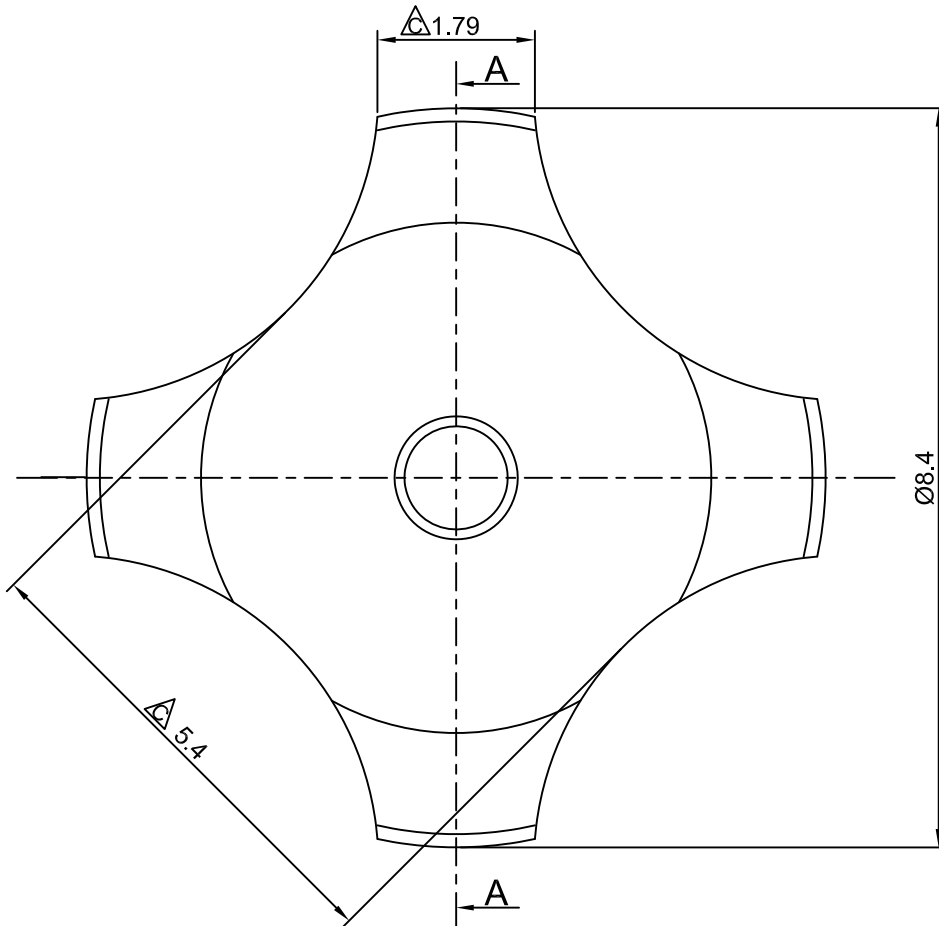

SECTION A-A



◆ SPECIFICATIONS

TRIP FORCE: 400 ± 30 g

CLICK RATIO: MIN 50 %

◆ TESTING CONDITIONS

FORCE TEST PROBE: HARD POINTED

LIFE TEST PROBE: RB 60° SILICON ROUND HEAD

LIFE TEST FORCE: 475 g

LIFE TEST SPEED: 180 CYCLE / MIN

BURR: MAX 0.05 MM

UNLESS OTHERWISE SPECIFIED TESTING METHOD

ACCORDING TO CROWN LINK STANDARD PROCEDURE

C	NEW DRAWING FORMAT & CORRECT DRAWING MISTAKES	ANNIE	2012.12.20	X.XX ±0.10
B	CONVERT TO NEW DRAWING FORMAT & REVISE DOME HEIGHT	ANNIE	2007.08.01	
A	FIRST DRAWING	ANNIE	2003.06.12	
REV/版本	MODIFIED CONTENT /變更內容	DRAWN/繪圖	DATE/日期	

DRAWN/繪圖	DATE/日期	CROWN LINK[®] THE LEADING MANUFACTURER OF FPC & FFC CONNECTOR, HOUSING AND DOME.				
ANNIE	2012.12.20	PRODUCT NAME/品名 METAL DOME				
CHECK BY/審查	DATE/日期	PART NO./料號	THICKNESS/厚度	SCALE/比例	SIZE/圖號	UNIT/單位
VIVIAN	2012.12.20	CL8.4-QSD-400T	0.08 mm	12:1	A4	mm
APPROVED BY/核准	DATE/日期	MATERIAL/材質		ANGLE OF VIEW/視角	SHEET/頁碼	REV/版本
JASON	2012.12.20	STAINLESS STEEL SUS 304		1 OF 1	1 OF 1	C
PACKAGE/包裝	10,000PCS/BAG					

D

D

C

C

B

B

A

A