

4

3

2

1

CROWN LINK[®]

專業薄膜開關連接器第一品牌

ROHS

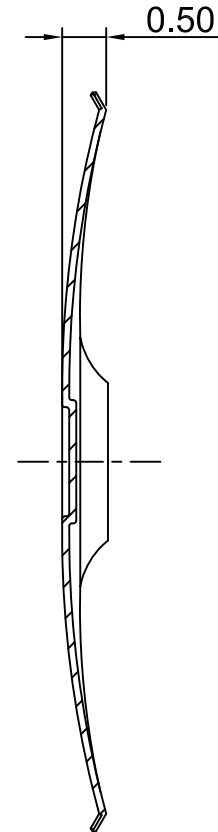
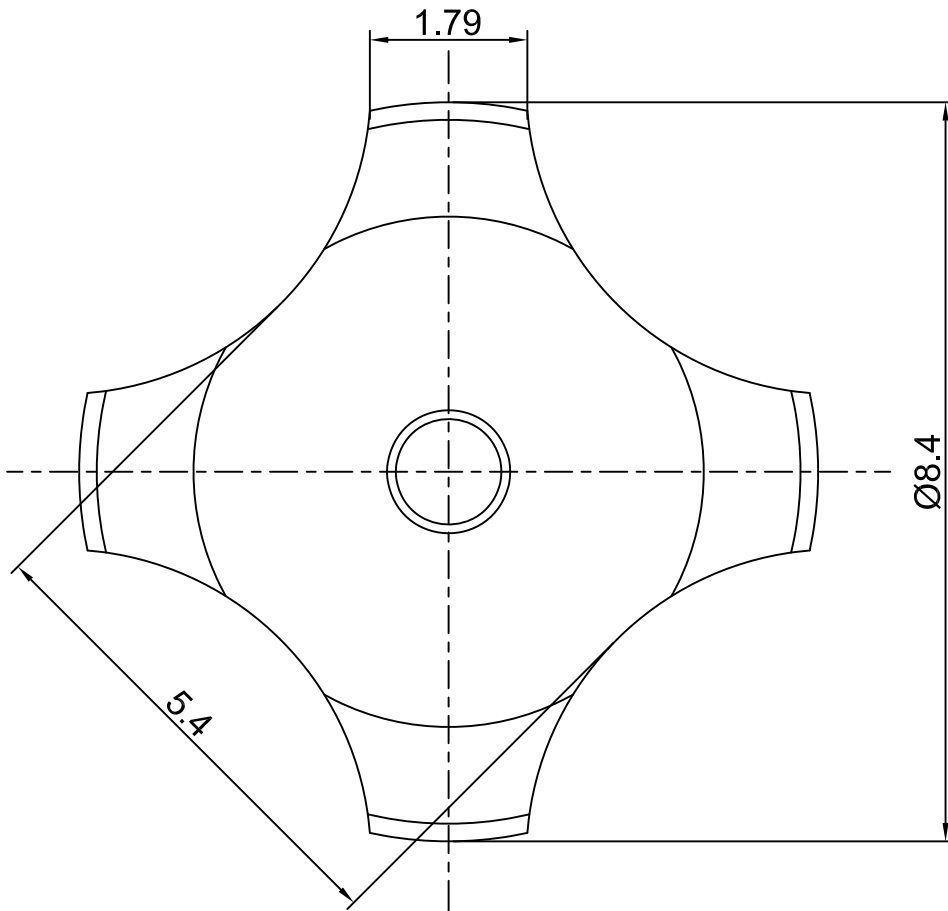

◆ SPECIFICATIONS

TRIP FORCE: 260 ± 30 g

CLICK RATIO: MIN 40 %

◆ TESTING CONDITIONS

FORCE TEST PROBE: HARD POINTED

LIFE TEST PROBE: RB 60° SILICON ROUND HEAD

LIFE TEST FORCE: 320 g

LIFE TEST SPEED: 180 CYCLE / MIN

BURR: MAX 0.05 MM

UNLESS OTHERWISE SPECIFIED TESTING METHOD
ACCORDING TO CROWN LINK STANDARD PROCEDURE

				X.XX ±0.10
B	NEW DRAWING FORMAT, CORRECT LEG WIDTH & BODY WIDTH	ANNIE	2012.11.13	
A	FIRST DRAWING	ANNIE	2012.11.13	
REV/版本	MODIFIED CONTENT /變更內容	DRAWN/繪圖	DATE/日期	
				TOLERANCE RANGE/公差範圍

DRAWN/繪圖	DATE/日期	CROWN LINK[®] THE LEADING MANUFACTURER OF FPC & FFC CONNECTOR, HOUSING AND DOME.				
ANNIE	2012.11.13	PRODUCT NAME/品名				
CHECK BY/審查	DATE/日期	METAL DOME				
VIVIAN	2012.11.13	PART NO./料號	THICKNESS/厚度	SCALE/比例	SIZE/圖號	UNIT/單位
APPROVED BY/核准	DATE/日期	CL8.4-QSD-260T	0.08 mm	12:1	A4	mm
JASON	2012.11.13	MATERIAL/材質		ANGLE OF VIEW/視角	SHEET/頁碼	REV/版本
PACKAGE/包裝	10,000PCS/BAG	STAINLESS STEEL SUS 304		1 OF 1	1 OF 1	B

D

D

C

C

B

B

A

A