

4

3

2

1

CROWN LINK[®]

專業薄膜開關連接器第一品牌

ROHS

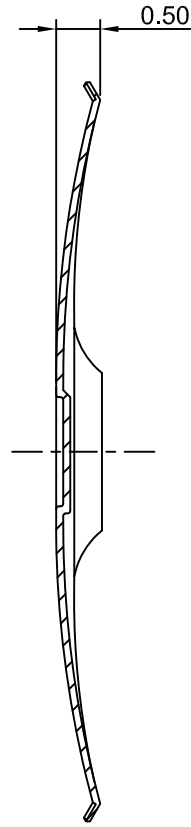
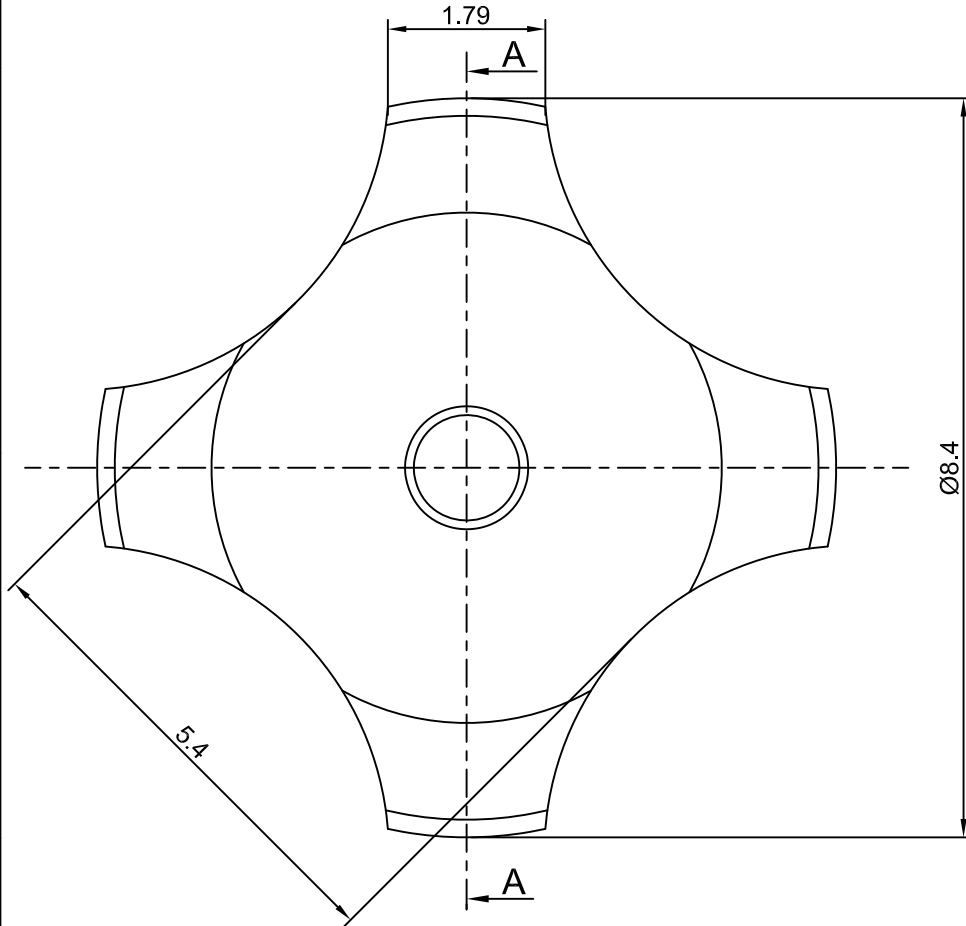

- ◆ SPECIFICATIONS
 - TRIP FORCE: 230 ± 30 g
 - CLICK RATIO: MIN 40 %
- ◆ TESTING CONDITIONS
 - FORCE TEST PROBE: HARD POINTED
 - LIFE TEST PROBE: RB 60° SILICON ROUND HEAD
 - LIFE TEST FORCE: 285 g
 - LIFE TEST SPEED: 180 CYCLE / MIN
 - BURR: MAX 0.05 MM
 - UNLESS OTHERWISE SPECIFIED TESTING METHOD ACCORDING TO CROWNLINK STANDARD PROCEDURE

SECTION A - A

| | | | | |
|--------|------------------------|----------|------------|----------------------|
| | | | | X.XX ± 0.10 |
| B | NEW DRAWING FORMAT | ANNIE | 2012.11.13 | |
| A | FIRST DRAWING | ANNIE | 2005.06.15 | |
| REV/版本 | MODIFIED CONTENT /變更內容 | DRAWN/繪圖 | DATE/日期 | |
| | | | | TOLERANCE RANGE/公差範圍 |

| | | | | | | | | |
|----------------|---------------|--|--------------|------------------|----------|---------|--|--|
| DRAWN/繪圖 | DATE/日期 | CROWN LINK[®] THE LEADING MANUFACTURER OF FPC & FFC CONNECTOR, HOUSING AND DOME. | | | | | | |
| ANNIE | 2012.11.13 | PRODUCT NAME/品名 METAL DOME | | | | | | |
| CHECK BY/審查 | DATE/日期 | PART NO./料號 | THICKNESS/厚度 | SCALE/比例 | SIZE/圖號 | UNIT/單位 | | |
| VIVIAN | 2012.11.13 | CL8.4-QSD-230T | 0.08 mm | 12:1 | A4 | mm | | |
| APPROVED BY/核准 | DATE/日期 | MATERIAL/材質 | | ANGLE OF VIEW/視角 | SHEET/頁碼 | REV/版本 | | |
| JASON | 2012.11.13 | STAINLESS STEEL SUS 304 | | | 1 OF 1 | B | | |
| PACKAGE/包裝 | 10,000PCS/BAG | | | | | | | |

D

D

C

C

B

B

A

A