

4

3

2

1

CROWN LINK[®]

專業薄膜開關連接器第一品牌

ROHS

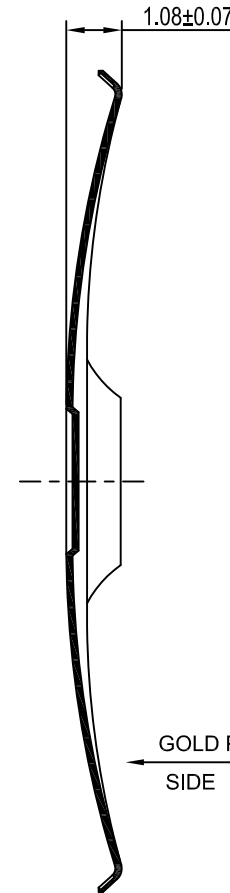
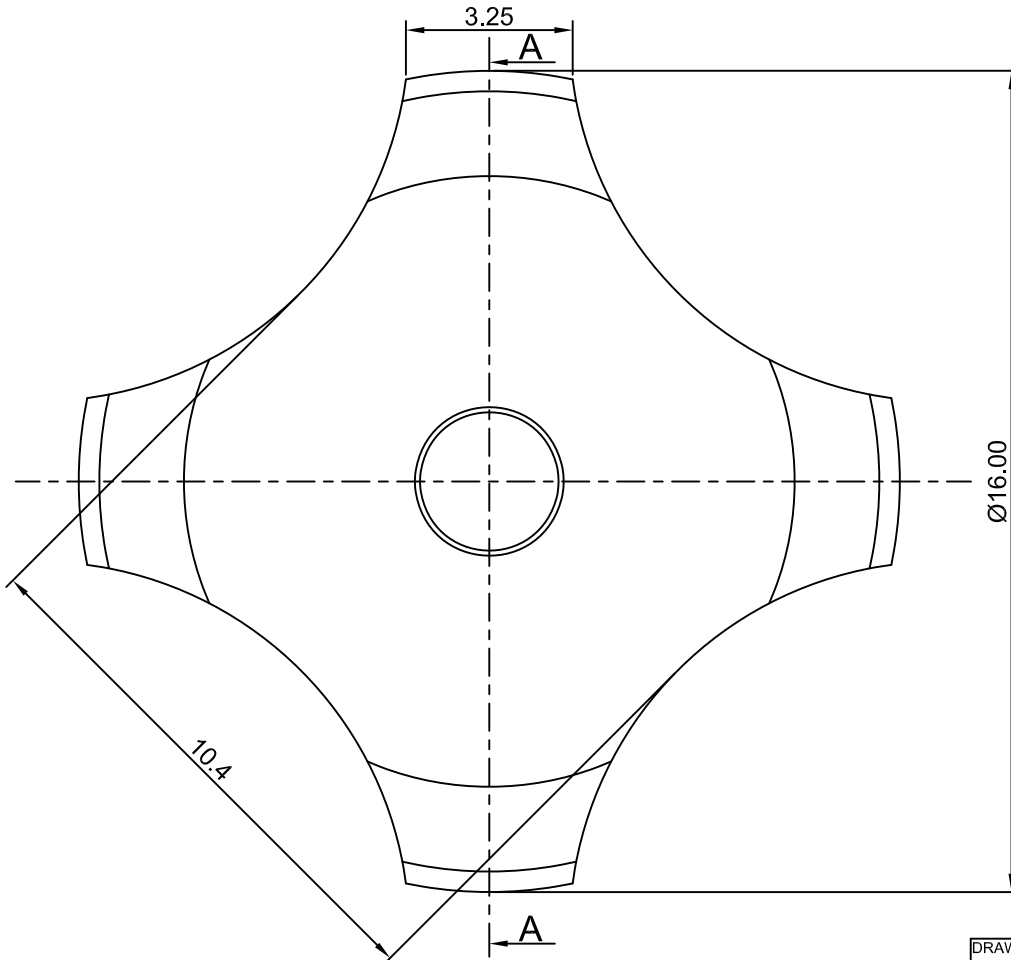

- ◆ SPECIFICATIONS
 - TRIP FORCE: 600 ± 30 g
 - CLICK RATIO: MIN 40 %
- ◆ TESTING CONDITIONS
 - FORCE TEST PROBE: HARD POINTED
 - LIFE TEST PROBE: RB 60° SILICON ROUND HEAD
 - LIFE TEST FORCE: 715 g
 - LIFE TEST SPEED: 180 CYCLE / MIN
 - BURR: MAX 0.05 MM
 - UNLESS OTHERWISE SPECIFIED TESTING METHOD ACCORDING TO CROWNLINK STANDARD PROCEDURE

SECTION A - A

				X.X ±0.10 X.XX ±0.05
B	ADD CONTACT LIFE SPECIFICATION	ANNIE	2013.09.13	
A	FIRST DRAWING	ANNIE	2013.02.20	TOLERANCE RANGE/公差範圍
REV/版本	MODIFIED CONTENT /變更內容	DRAWN/繪圖	DATE/日期	

DRAWN/繪圖	DATE/日期	CROWN LINK[®] THE LEADING MANUFACTURER OF FPC & FFC CONNECTOR, HOUSING AND DOME.				
ANNIE	2013.09.13	PRODUCT NAME/品名 METAL DOME				
CHECK BY/審查	DATE/日期	PART NO./料號	THICKNESS/厚度	SCALE/比例	SIZE/圖號	UNIT/單位
VIVIAN	2013.09.13	CL16-QGD-600T	0.12 mm	7:1	A4	mm
APPROVED BY/核准	DATE/日期	MATERIAL/材質	ANGLE OF VIEW/視角	SHEET/頁碼	REV/版本	
JASON	2013.09.13	SINGLE SIDE GOLD PLATED STAINLESS STEEL SUS 304	⊕	1 OF 1	B	
PACKAGE/包裝	10,000PCS/BAG					

D

D

C

C

B

B

A

A