

4

3

2

1

CROWN LINK[®]

專業薄膜開關連接器第一品牌

ROHS

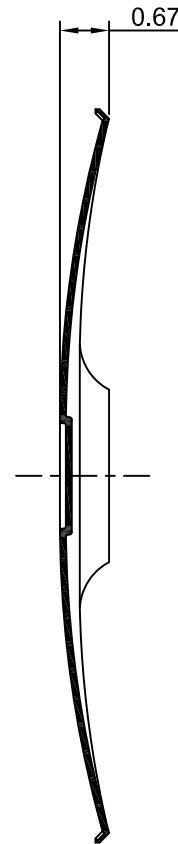
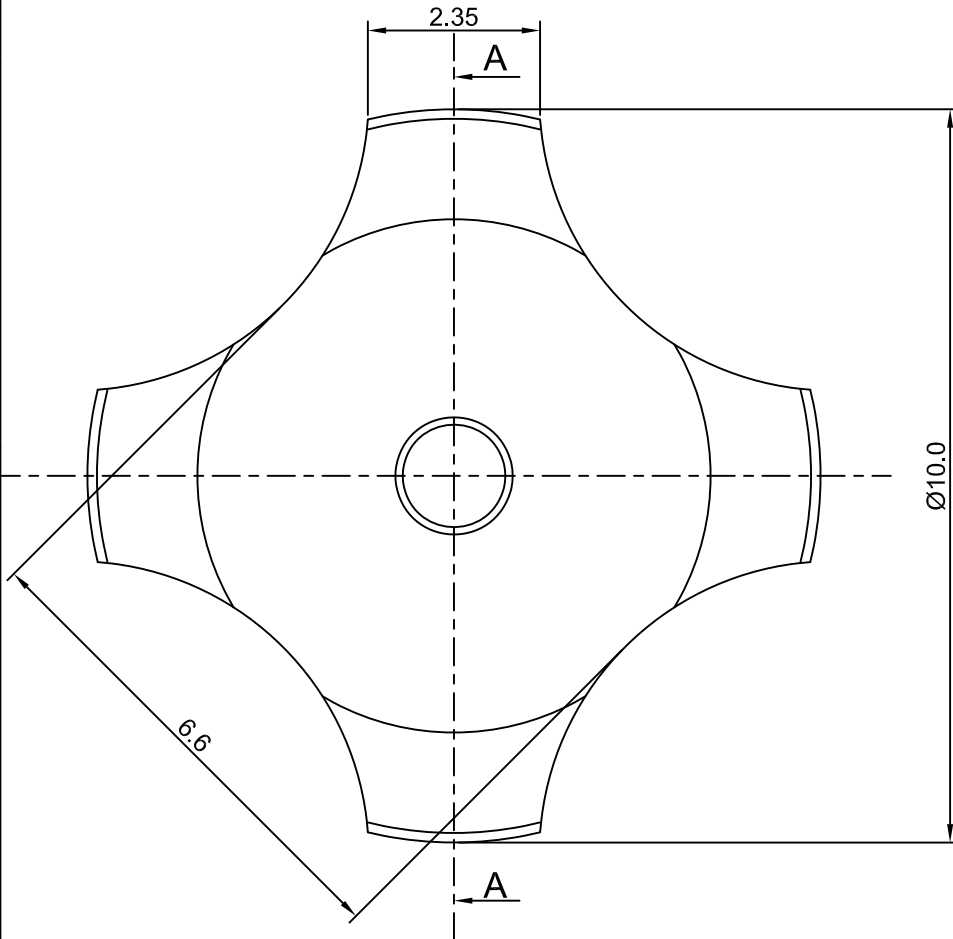

◆ SPECIFICATIONS

TRIP FORCE: 350 ± 30 g

CLICK RATIO: MIN 45 %

◆ TESTING CONDITIONS

FORCE TEST PROBE: HARD POINTED

LIFE TEST PROBE: RB 60° SILICON ROUND HEAD

LIFE TEST FORCE: 420 g

LIFE TEST SPEED: 180 CYCLE / MIN

BURR: MAX 0.05 MM

UNLESS OTHERWISE SPECIFIED TESTING METHOD

ACCORDING TO CROWNLINK STANDARD PROCEDURE

SECTION A - A

				X.XX ±0.10
B	NEW DRAWING FORMAT	ANNIE	2012.07.24	
A	FIRST DRAWING	Vivian	2007.01.29	
REV/版本	MODIFIED CONTENT /變更內容	DRAWN/繪圖	DATE/日期	
				TOLERANCE RANGE/公差範圍

DRAWN/繪圖	DATE/日期	CROWN LINK[®] THE LEADING MANUFACTURER OF FPC & FFC CONNECTOR, HOUSING AND DOME.						
ANNIE	2012.07.24	PRODUCT NAME/品名 METAL DOME						
CHECK BY/審查	DATE/日期	PART NO./料號	THICKNESS/厚度	SCALE/比例	SIZE/圖號	UNIT/單位		
VIVIAN	2012.07.24	CL10-QND-350T	0.08 mm	10:1	A4	mm		
APPROVED BY/核准	DATE/日期	MATERIAL/材質		ANGLE OF VIEW/視角	SHEET/頁碼	REV/版本		
JASON	2012.07.24	DOUBLE SIDE NICKEL PLATED STAINLESS STEEL SUS 304		10°	1 OF 1	B		
PACKAGE/包裝	10,000PCS/BAG							

D

D

C

C

B

B

A

A