

4

3

2

1

CROWN LINK[®]

專業薄膜開關連接器第一品牌

ROHS

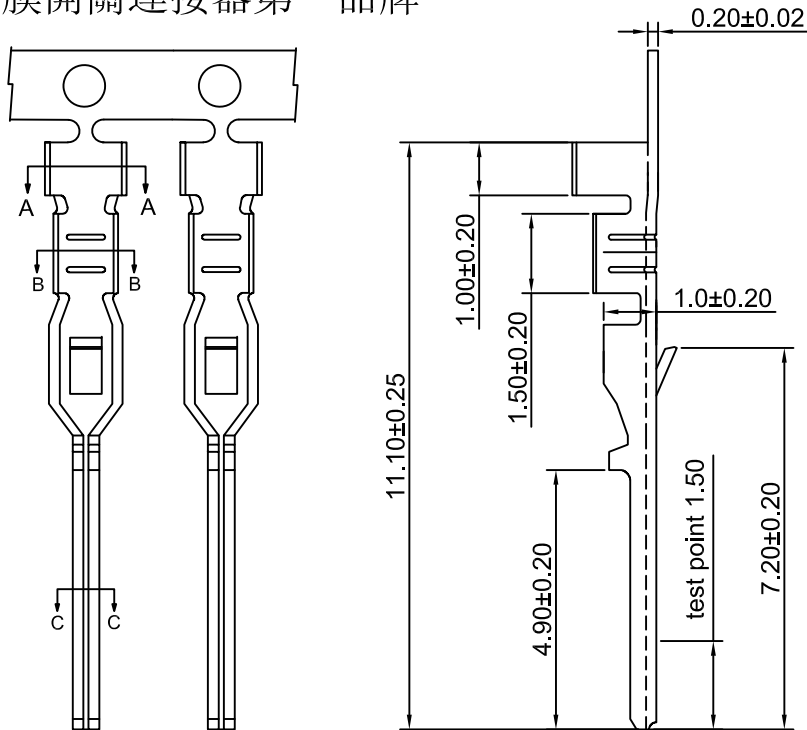

◆ FOR 2001H SERIES HOUSING

◆ SPECIFICATIONS

VOLTAGE RATING: 250V AC,DC

CURRENT RATING: 2A AC,DC

WITHSTANDING VOLTAGE: 800V AC / MINUTE

INSULATION RESISTANCE: 1000 MΩ MIN

CONTACT RESISTANCE: 20mΩ MAX

TEMPERATURE RANGE: -40°C~+105°C

◆ APPLICABLE WIRE: AWG26#-28#

◆ PART NO.

2001- 15K - 0T - M P

SERIES NO.

15K/REEL

MOLD NO.

MALE

0T:TIN PLATED.

OTHER PLATINGS ON REQUEST.

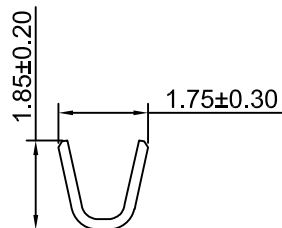

A-A SECTION

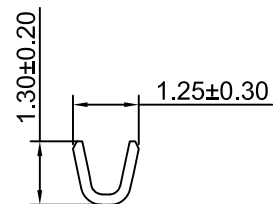

B-B SECTION

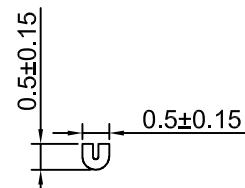

C-C SECTION

DRAWN/繪圖 JUDY	DATE/日期 2023.08.05	CROWN LINK[®] THE LEADING MANUFACTURER OF FPC & FFC CONNECTOR, HOUSING AND DOME.			
CHECK BY/審查 VIVIAN	DATE/日期 2023.08.05	PRODUCT NAME/品名 2.00mm PITCH CONNECTOR FOR CABLE			
APPROVED BY/核准 WENDY	DATE/日期 2023.08.05	PART NO./料號 2001-15K-0T-MP	SCALE/比例 8:1	SIZE/圖號 A4	UNIT/單位 mm
PACKAGE/包裝	15,000PCS/REEL	MATERIAL/材質 PHOSPHOR BRONZE	ANGLE OF VIEW/視角 	SHEET/頁碼 1 OF 1	REV/版本 A

X: ±0.50 X": ±1"
X: ±0.30 X": ±0.1"
XX: ±0.20 XX": ±0.01"
XXX: ±0.05 XXX": ±0.005"

TOLERANCE RANGE/公差範圍

REV/版本	MODIFIED CONTENT /變更內容	DRAWN/繪圖	DATE/日期